



VOICE and DATA Gateway





Gateway Purpose

- **Re formats Voice and Data Streams to/from the ToIP Network**
- **Allows Voice and Data Traffic to be interfaced to the CAD and ACOM**



Traffic Handling

- **Audio Gateway Ports**

- » 4 x 2MB E1 ACOM Connection
- » 1 x 100 Base T Ethernet ISR Connection

- **Data Gateway Ports**

- » 1 x 100 Base T Ethernet CAD Connection
- » 1 x 100 Base T Ethernet ISR Connection

- **Protocols**

- » ACOM protocol over HDLC
- » CAD protocol over TCP/IP
- » SAP protocol over TCP/IP
- » SNMP v2.c for basic alarms to the NMS for logging



Voice Gateway Architecture

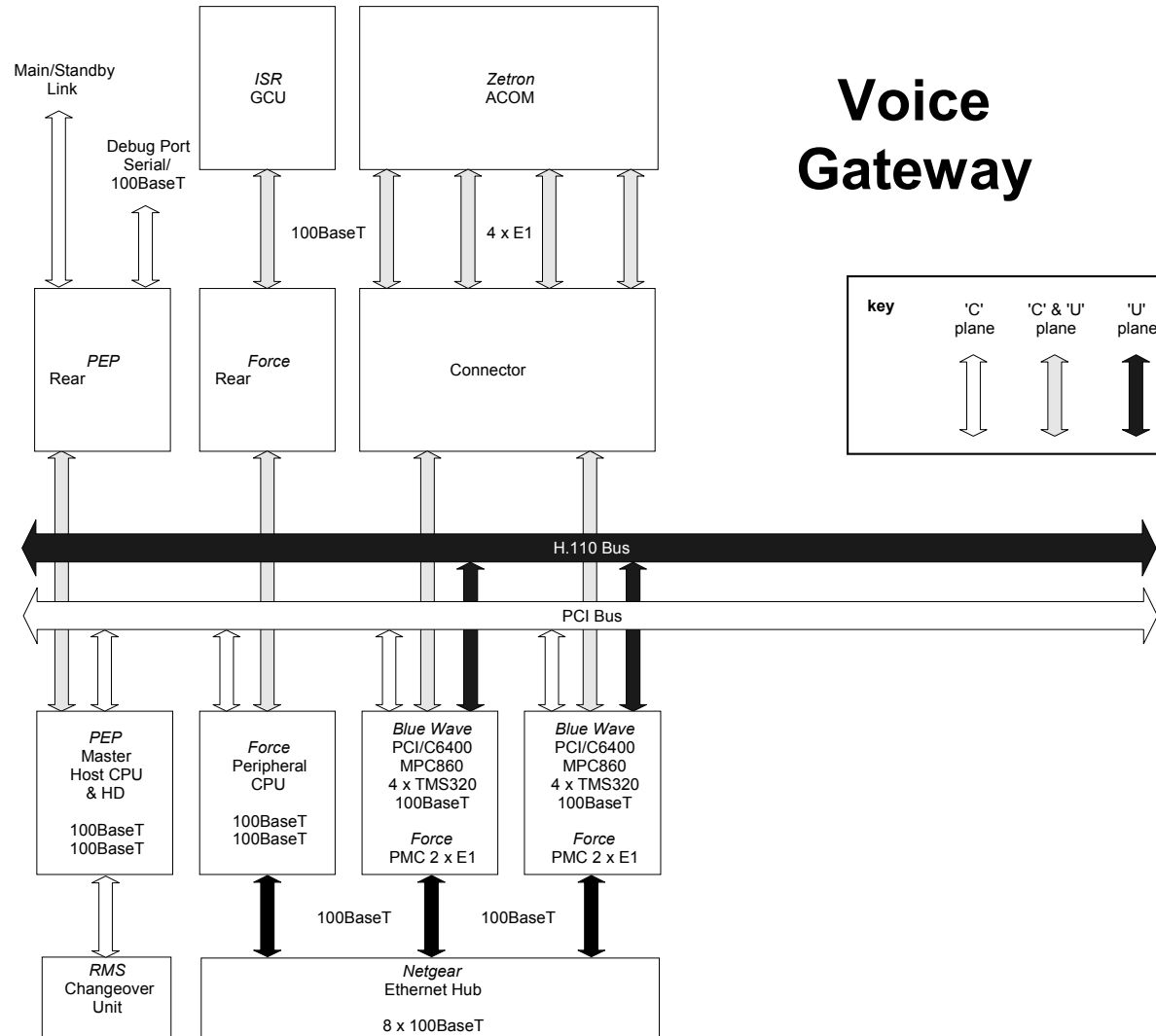

Data Gateway Architecture

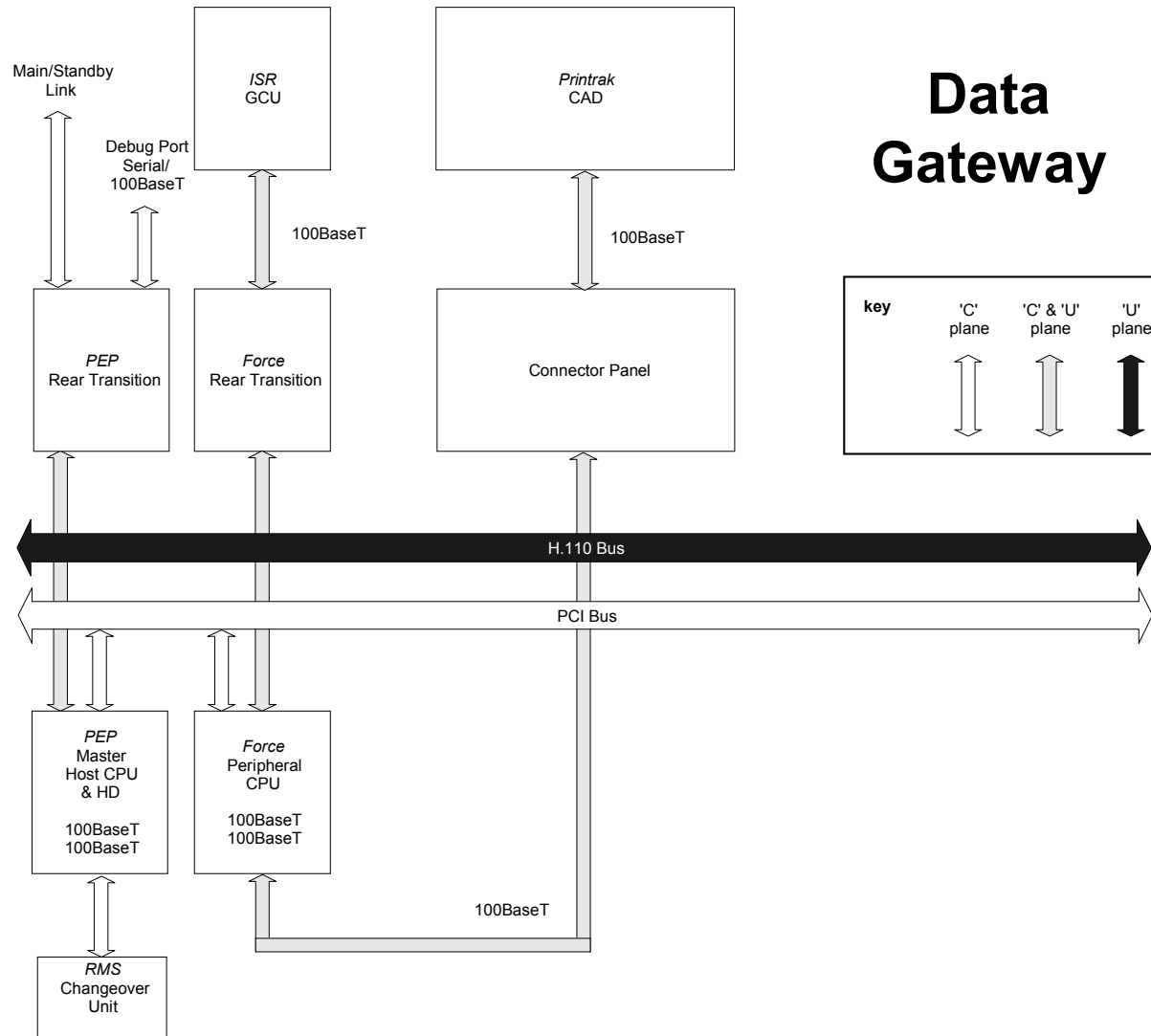

Gateway Components 1 of 2

- **Rack Assembly**
 - PEP Custom Build 6RU
- **PSU**
 - PEP CP6 250W AC Input (O/p's 3.3v, 5v, 12v and -12v)
- **Host CPU**
 - PEP CP602 500Mhz Pentium and Peripherals
- **Rear Transition Card**
 - PEP I/O PCB Assembly
- **Peripheral CPU**
 - Force PowerPC 400Mhz CPU + 128Mb Ram



Gateway Components 2 of 2

- **Rear Transition Card**

- Force Rear I/O Assy

- **DSP Cards**

- Blue Wave cCpi 6400
- 4x TMS62SC201
- MPC860T CPU

- **PMC E1 Card**

- Force PMC/860
- 2 x E1 Interfaces
- MPC860MH CPU

- **Drives**

- CD ROM
- Floppy
- 6GB Hard Drive
- 16Mb Flash Disk

- **Hub**

- Netgear 8 Port Rack Mount



PEP Backplane Rear View

- Refer to Page 37 - 39 of O&M Manual for all Front and Rear Connections

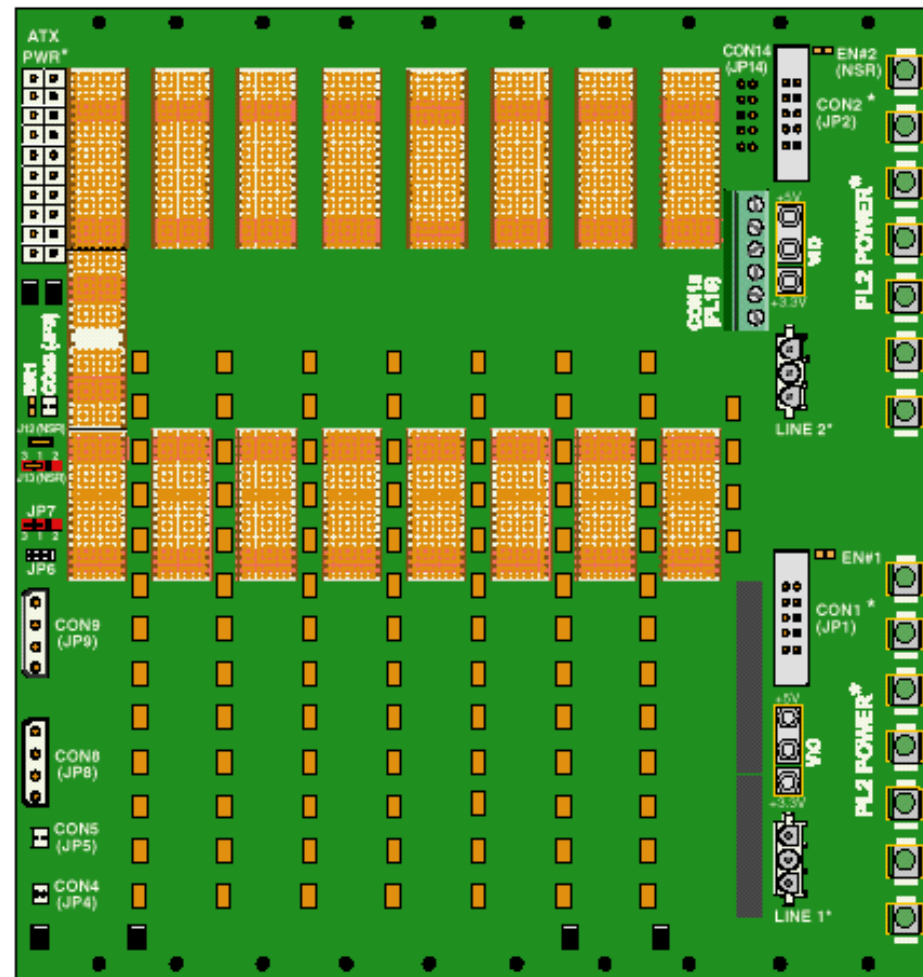

Host CPU Card PEP CCP1602

- **Pentium Host Card**

- PC on a Card with BIOS, IDE and Floppy Interface, Serial, Parallel and Ethernet Ports
- I/O is mainly routed to the Peripheral Processor Card via the rear Transition Card

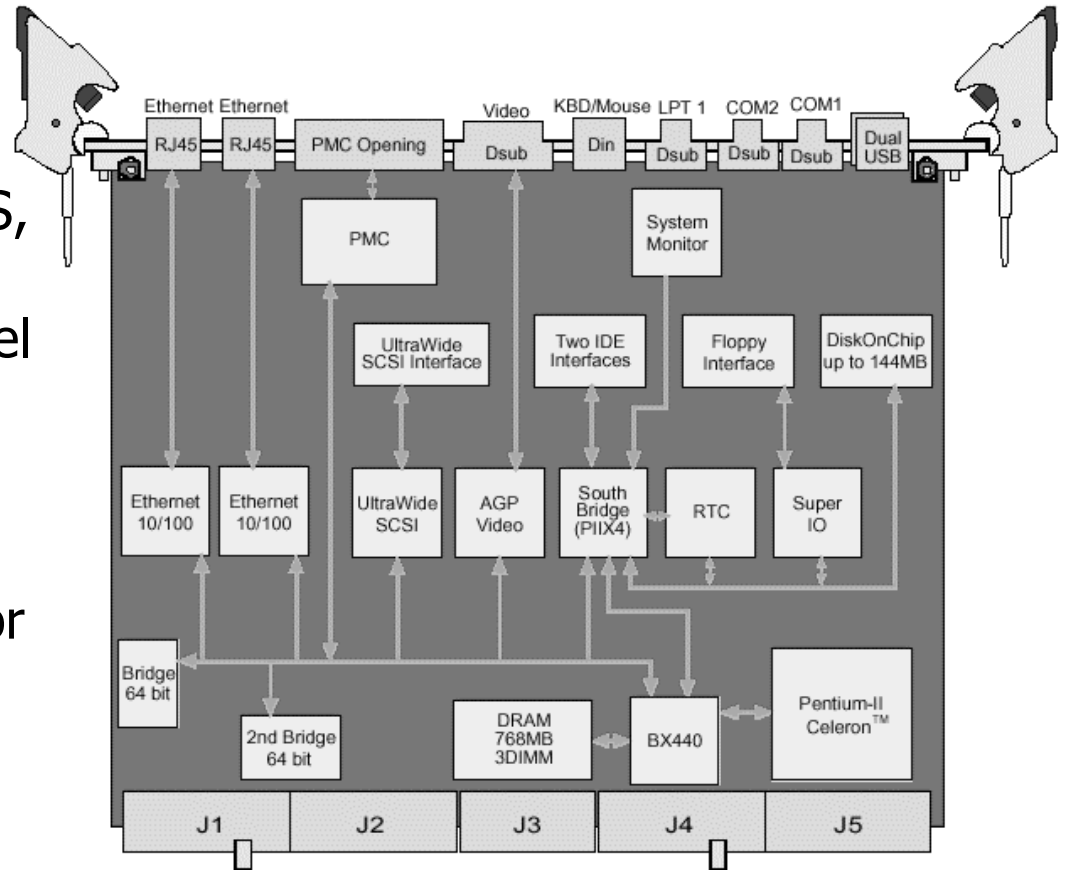

Rear Transition Card

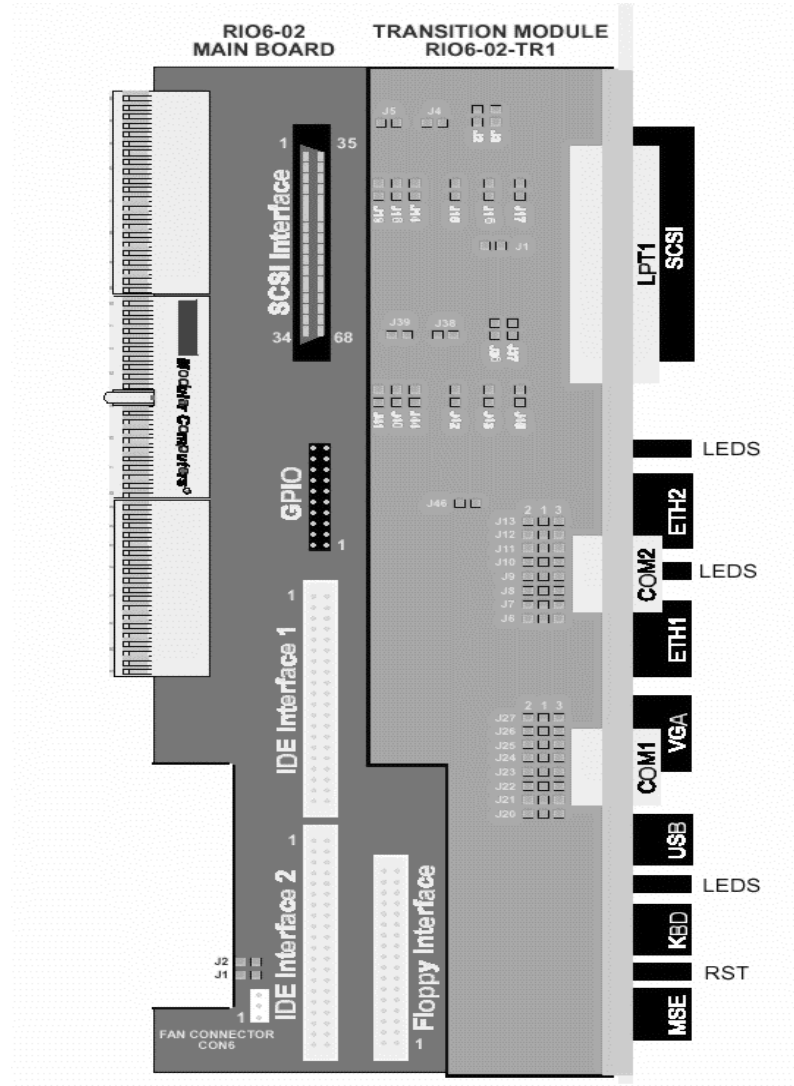

Peripheral Force 680 CPU Card

- **Connected to Main Bus via Non Transparent PCI-PCI Bridge**
- **Peripherals Appears as Single Device to Host**
- **Consists of:**
 - Power PC with RAM etc
 - 2 x Ethernet Ports
 - 2 x PMC Modules

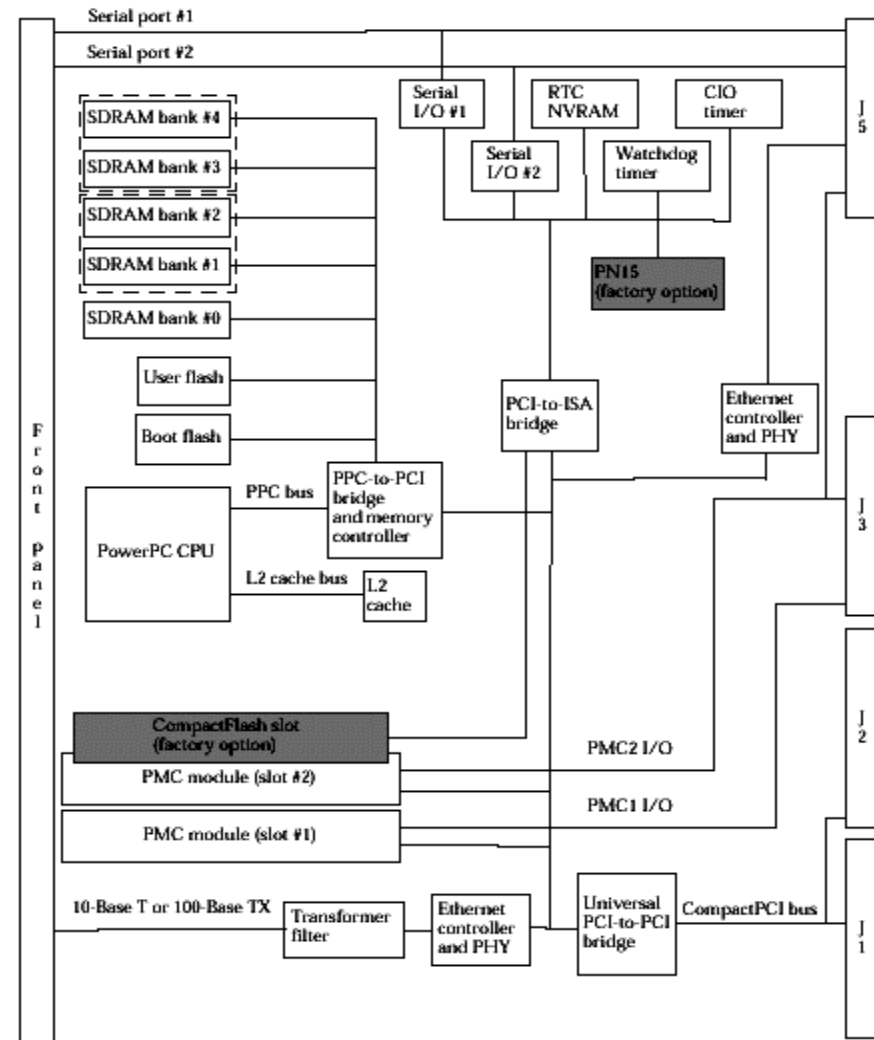

DSP Card - BlueWave CCPI6400

- **Heart of the Voice Rack**
- **Provides Encode / Decode of ACOM PCM Traffic to ACELP Tetra Format**
- **Consists of:**
 - 4 x Texas DSPs
 - Motorola CPU
 - Lucent TDM Switch IC

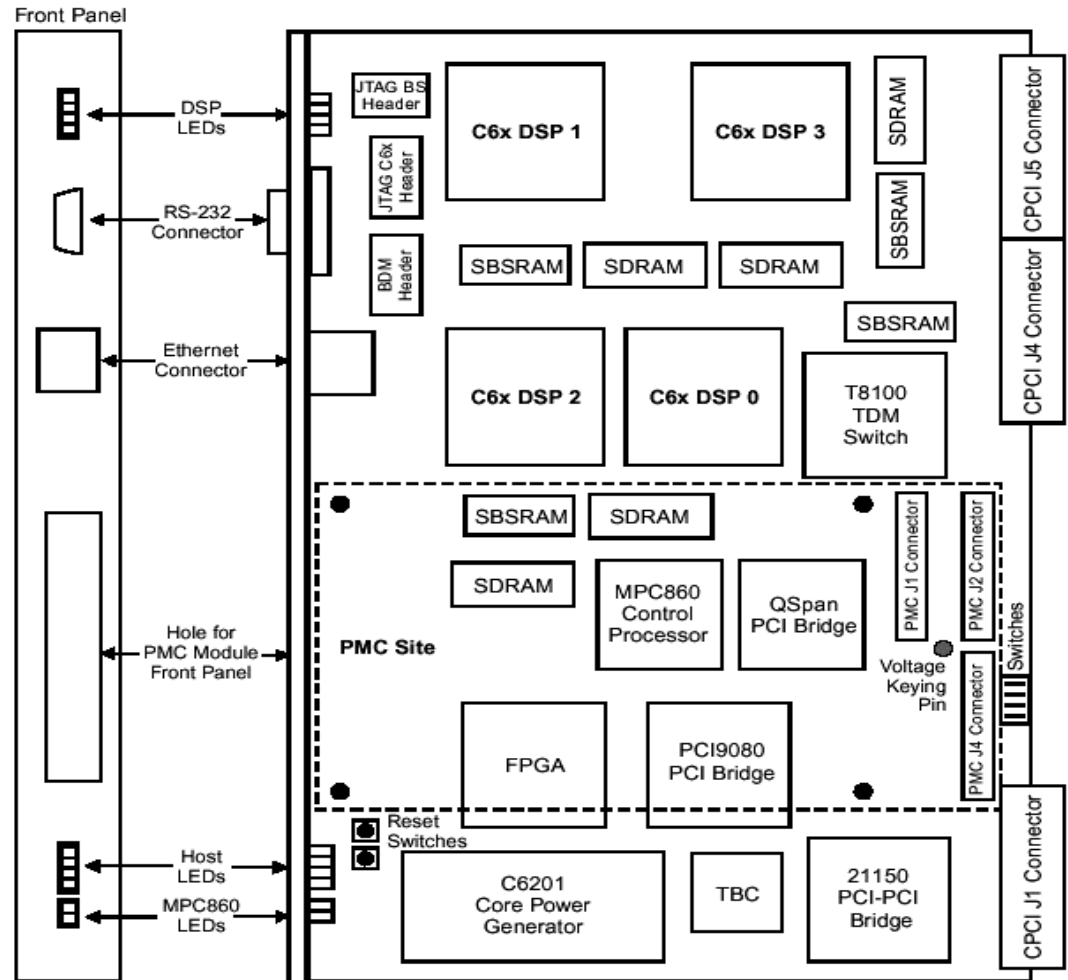

Voice TDM Data Stream (DSP and E1 Cards)

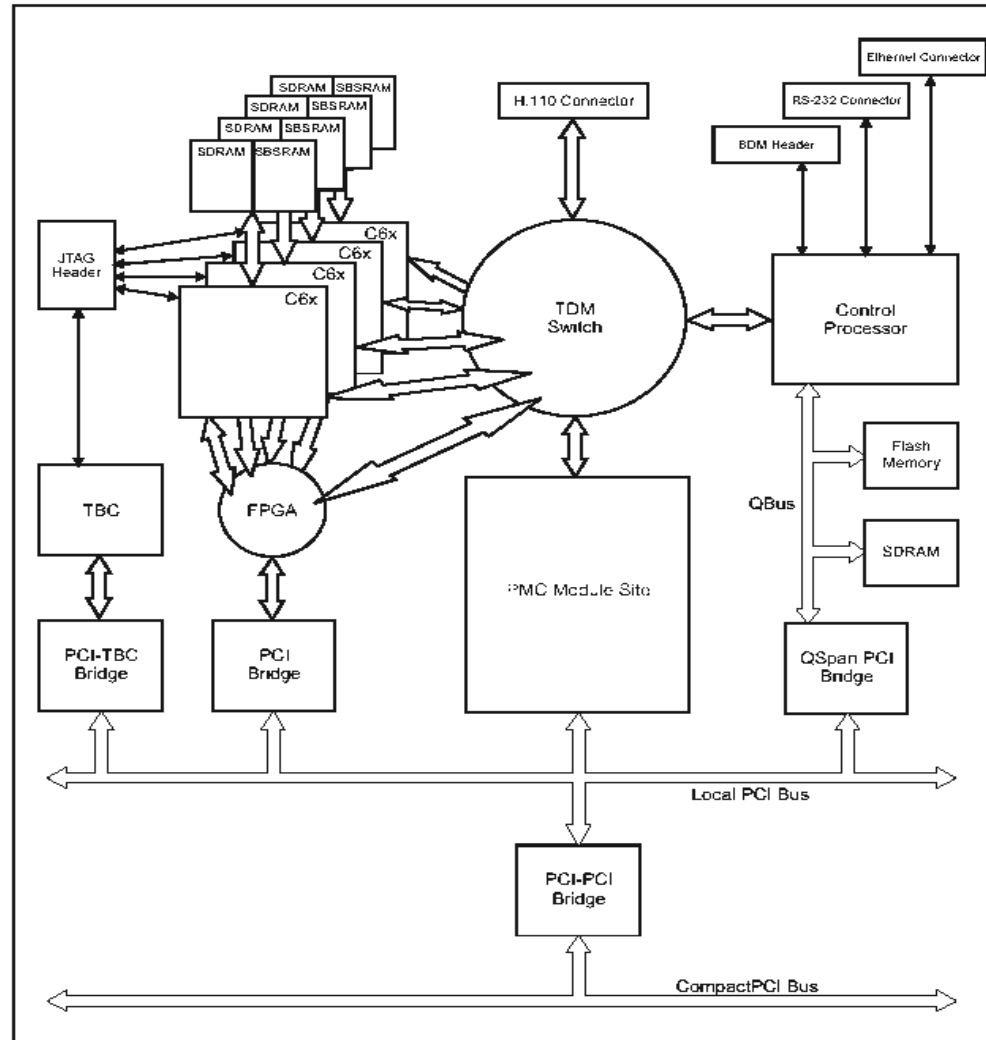

PMC E1 Card

- **Consists of:**

- E1 Physical Interface
- PMC-Sierra PM6341 Framers
- MPC860 CPU+DRAM, SRAM and FLASH EPROM
- SC4000 SCBus Controller / TDM time slot Assigner
- QSPAN PCI Bus Interface

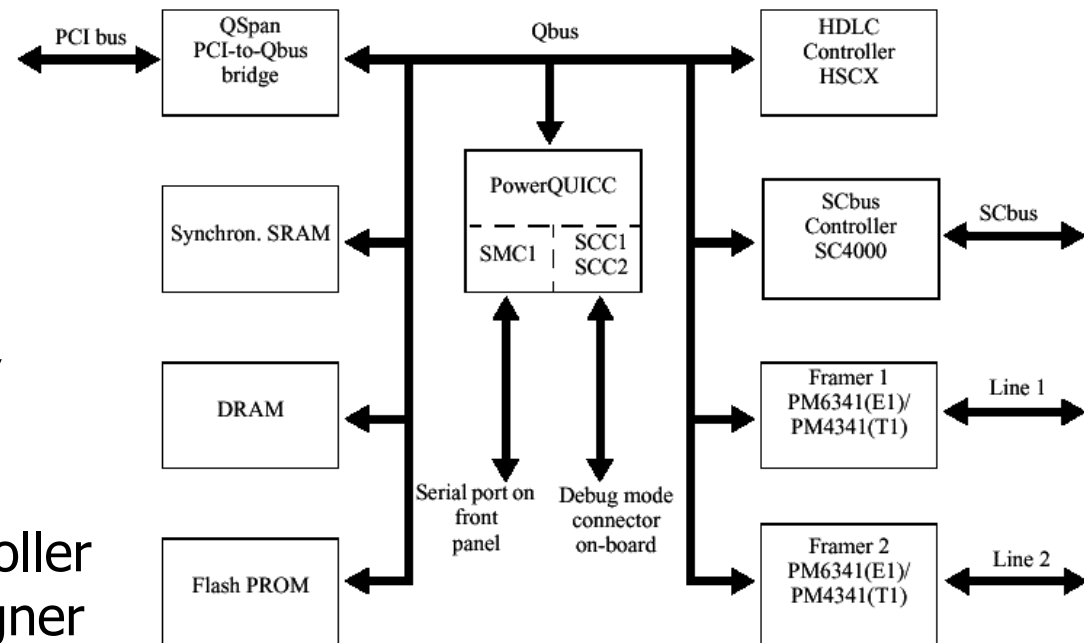

Rack Changeover Unit

- **Fitted to Inside Rear of Ccpi Rack**
- **Monitors Rack Status and facilitates a Changeover**
- **Failure Triggers are:**
 - Hardware
 - Software
 - Power
- **Change over is Triggered by Relay De energising**

